

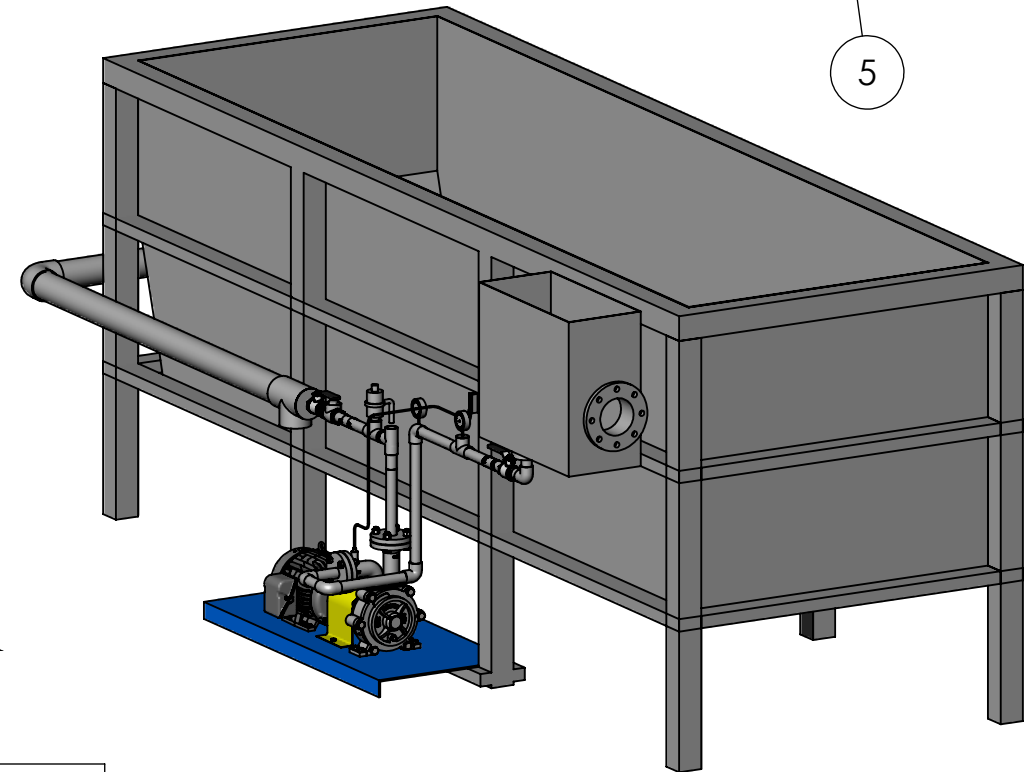

**GENERAL NOTES**

- 1) MAX RGT PUMP FLOODED SUCTION ONLY.
- 2) OBSERVE ALL SAFETY PRECAUTIONS.
- 3) NEVER PUMP AGAINST CLOSED VALVES.
- 4) PROTECT PUMP FROM FOREIGN OBJECTS.
- 5) ALWAYS USE RELIEF VALVE.
- 6) RECOMMEND PUMP SUCTION & DISCHARGE PIPING IS LINEAR 3-5X DIAMETER.



#	DESCRIPTION
1	BALL VALVE (SIZE TBD)
2	VACUUM GAGE - 30 TO 0 inHg
3	FLOW METER 10-100 SCFH - COMPRESSED AIR, 5-7 PSI
4	AIR INJECTION BALL CHECK
5	MAX RGT PUMP (SIZE TBD)
6	PRESSURE GAGE 0 TO 160 PSI
7	RELIEF VALVE 125 PSI
8	BALL VALVE (SIZE TBD)
9	SWING CHECK
10	DISSOLVED AIR FLOTATION UNIT
11	CLEAR WELL

REV	REVERSION DESCRIPTION	DATE	SIGNATURE

CUSTOMER: EXAMPLE		 Rogue Pump Company, LLC 19215 SE 34th Street Suite 106-202 CAMAS, WA 98607	
<small>THE INFORMATION HEREIN IS PROPRIETARY TO ROGUE PUMP COMPANY, LLC. NO PORTION OF IT SHALL BE COPIED, DISCLOSED OR USED FOR DESIGN OR MANUFACTURE EXCEPT WITH SPECIFIC WRITTEN CONSENT FROM ROGUE PUMP COMPANY</small>		TITLE: <b>AERATION UPGRADE MAX RGT PUMP GENERAL LAYOUT</b>	
DRAWN BY: REW	DRAWING SIZE <b>B</b>	DRAWING NO. R-16-A01-AERATION	REV
CERTIFIED:	DATE: 9/18/2019	SCALE: N/A	SHEET: 1 OF 1

**CONFIDENTIAL**